



OSF 50/63



Pressacavi divisibili

CARATTERISTICHE

- Filettatura metrica M50 o M63
- Senza viti
- Protezione IP54
- Controdado e guarnizione compresi nella fornitura
- Colori disponibili: grigio e nero

I pressacavi divisibili OSF 50 e OSF 63 sono dotati di filettatura metrica e sono particolarmente indicati per l'utilizzo con cavi con connettori.

Lo stesso telaio può essere equipaggiato con 4 gommini SPC piccoli e multipli per cavi da 1 a 15 mm di diametro oppure con 1 gommino grande SPL per cavi da 12 a 29.

Materiale: PC, senza alogeni e siliceni

Infiammabilità: autoestinguente sec. UL94-V0

Temperatura: -40°C... +130°C (statica)

PRODOTTI CORRELATI

- Gommini SPC (da pag. 53)
- Gommini SPL (da pag. 56)
- Punzonatrice HY360 e punzoni (pag. 174)
- Controdadi divisibili (pag. 50)



Modello	Codice	Apertura max. (mm)	Gommino limite consentito				Pz (x conf.)
OSF 50G	1731052350	50,5	SPC 14	SPC 2 x 6	SPC 4 x 6	SPL 29	10
OSF 63G	1731052363	63,5	SPC 14	SPC 2 x 6	SPC 4 x 6	SPL 29	
OSF 50B	1731052450	50,5	SPC 14	SPC 2 x 6	SPC 4 x 6	SPL 29	
OSF 63B	1731052460	63,5	SPC 14	SPC 2 x 6	SPC 4 x 6	SPL 29	

Alcune configurazioni possibili

Dimensioni (mm)

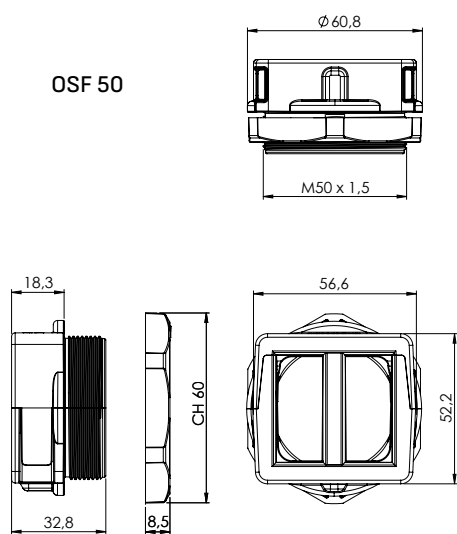

OSF 63

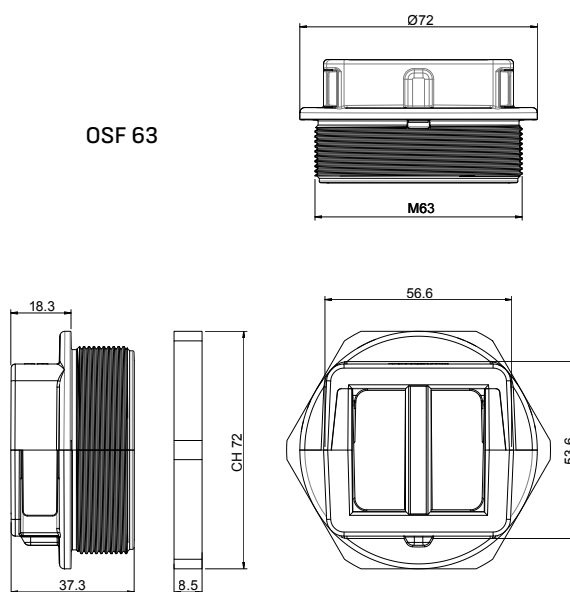

Tutorial



IP54

NEMA 12



IK10