



# DES 16M



## Splittable frame for cables with and without connectors

NEW

- ▶ Multiple configurations with small and big grommets
- ▶ Frame screws in AISI304 Stainless Steel
- ▶ External gasket included
- ▶ Strain relief according to EN 62444
- ▶ Sturdy construction IK10
- ▶ Threaded inserts version on request

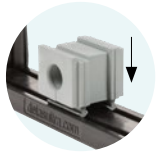

Model	Code	Some possible configurations	Max. cut-out [mm]	Pcs /pack
DES 16M	1731010216		86 x 40	10
Upon request:	1731991020	Set of 4 mounting screws in AISI304 with Black Dacromet finishing		10

The DES 16M splittable frame allow up to 32 cables with or without connector or one or two cables up to 35mm diameter to pass through electric cabinet or machines walls.

The small and big grommets can be freely positioned inside the frame.

The DES 16M frame is the base structure for the expandable MX version.

### Technical data

**Material:** PP+GF

**Flammability:** self-extinguishing acc. to UL94-V0

**Temperature:** -40°C... +155°C (static)

**Features:** halogens and silicones free

### Related products

SPG grommets (from page 38)

SPP grommets (from page 31)

DES Cover

HY360 hydraulic punch driver

### Dimensions [mm]

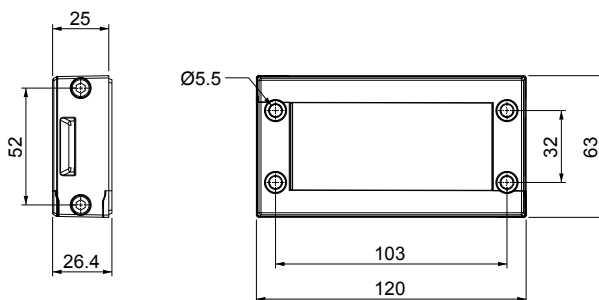

IP54

NEMA 12



ECOLAB



IK10