



## SPN grommets – large with extended range

### FEATURES

- Large grommets for cables from 11,5 to 31 mm diameter
- Suitable for DES LC24, LC16, LC10 and LCQ frames only
- “Blind” version available
- Grey and black colours available
- UL94-V0 for both colours
- IP54

SPN is the new family of large multi-range grommets designed for the DES LC24, LC16, LC10 and LCQ frames. The range covers cable diameters from 11,5 mm to 31 mm with only five models.

The SPN 2R1 can accommodate two cables with a diameter of 16–17 mm.

**Material:** TPE, halogen-free, silicone-free  
**Flammability:** self-extinguishing acc. to UL94-V0 (grey or black)  
**Temperature:** -40°C... +110°C (static)

*Material successfully tested for UV and water exposure resistance according to UL 746C related procedures, suitable for outdoor applications.*

### RELATED PRODUCTS

- DES LC24
- DES LC16
- DES LC10
- DES LCQ

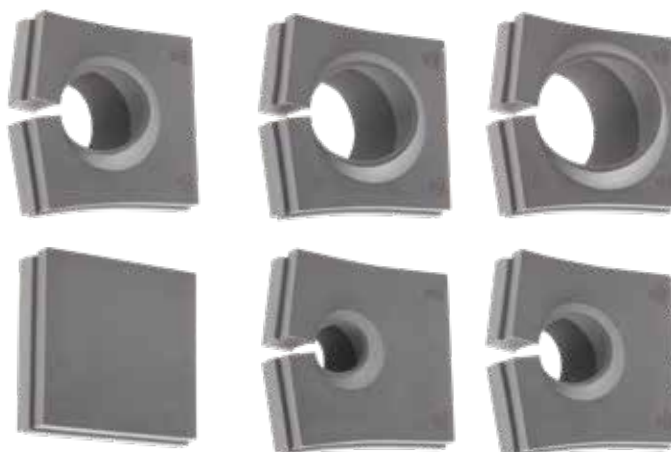
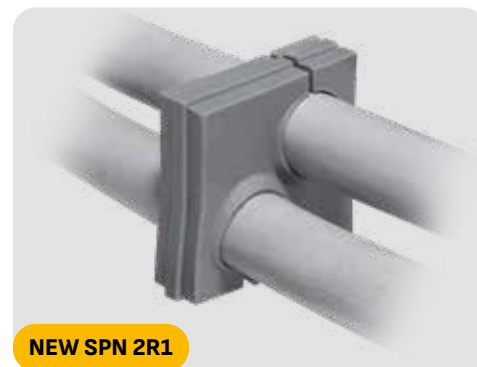

| Model          | Code       | Model          | Code       | Ø Cable (mm) | Pcs (/pack) |
|----------------|------------|----------------|------------|--------------|-------------|
| <b>SPN 0G</b>  | 1731053110 | <b>SPN 0B</b>  | 1731053140 | “Blind”      | 10          |
| <b>SPN 13G</b> | 1731053115 | <b>SPN 13B</b> | 1731053145 | 11,5-16      |             |
| <b>SPN 17G</b> | 1731053120 | <b>SPN 17B</b> | 1731053150 | 16-20        |             |
| <b>SPN 21G</b> | 1731053125 | <b>SPN 21B</b> | 1731053155 | 20-24        |             |
| <b>SPN 25G</b> | 1731053130 | <b>SPN 25B</b> | 1731053160 | 24-28        |             |
| <b>SPN 29G</b> | 1731053135 | <b>SPN 29B</b> | 1731053165 | 28-31        |             |

### Dimensions (mm)

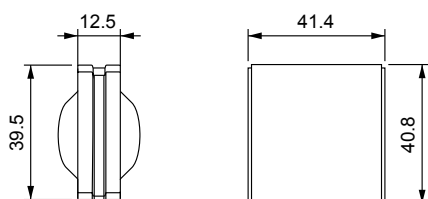

| Model           | Code       | Cable diameter range (mm) | Pcs (/pack) |
|-----------------|------------|---------------------------|-------------|
| <b>SPN 2R1G</b> | 1731053137 | (2x) 16-17                | 10          |
| <b>SPN 2R1B</b> | 1731053167 | (2x) 16-17                |             |



**IP54**

**NEMA 12**



**ECOLAB**

**UL94-V0**



**RoHS COMPLIANT**