



# DES PMH 24



Cable entry plates with internal frame and double membrane

## FEATURES

- Compact dimensions, ultra-thin
- For a large number of cables without connectors
- High strain relief thanks to the double membrane
- Space saving and cost-effective solution
- IP66
- Threaded inserts version on request

The DES PMH 24 is an innovative alternative to standard cable glands for machinery cabinets and equipment. Its ultra-thin design allows installation in confined spaces while maintaining excellent stability thanks to the integrated rigid frame. The cable is inserted through the front membrane, while the second membrane enhances strain relief and ensures a liquid-tight seal.

**Material:** TPE+PA66, halogen-free, silicone-free

**Flammability:** self-extinguishing acc. to UL94-V0

**Temperature:** -40°C... +105°C (static)

*Material successfully tested for UV and water exposure resistance according to UL 746C related procedures, suitable for outdoor applications.*

## RELATED PRODUCTS

- IFP plugs (page 117)
- Intumescent gasket (page 178)

**NC:** Number of cables

**ØC:** Diameter of cables - max (mm)



Double membrane

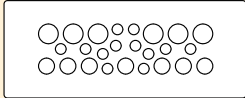

NEW	Model	Code		NC	ØC
	DES PMH 24/25G	1732024025			6
Cut-out (mm)	Plate (mm)	Pcs/pack		7	4,8 / 9,7
112 x 36	148,6 x 59,6	10		7	3,2 / 6,5

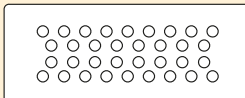
NEW	Model	Code		NC	ØC
	DES PMH 24/34G	1732024034			34
Cut-out (mm)	Plate (mm)	Pcs/pack			
112 x 36	148,6 x 59,6	10			

NEW	Model	Code		NC	ØC
	DES PMH 24/3G	1732024003			3
Cut-out (mm)	Plate (mm)	Pcs/pack			
112 x 36	148,6 x 59,6	10			

## Dimensions (mm)

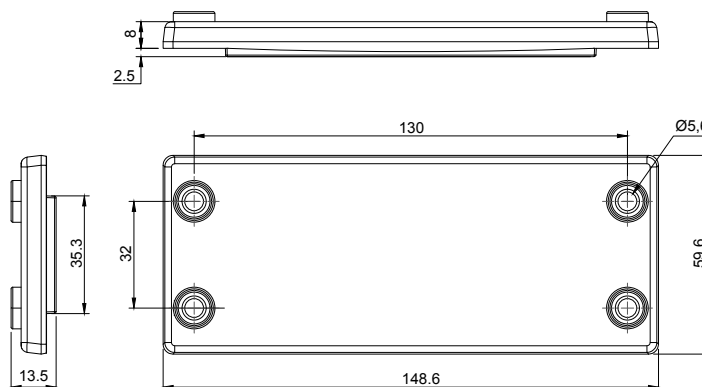

IP66



ECOLAB

