



NEW

DES LC16

Splittable frame for cables with and without connectors

FEATURES

- For SPC and SPN grommets
- Stainless steel screws
- Strain relief according to EN 62444
- IP54
- Integrated UL94-V0 gasket
- Removable divider for small or large grommets in the same frame

The DES LC16 is a split cable entry frame designed for quick and flexible routing of cables with or without connectors. It supports both small and large grommets of the SPC and SPN ranges, allowing multiple cable configurations. The frame features a pre-assembled gasket for direct mounting onto the cabinet, and is secured using stainless steel screws.

Material: PP+GF, halogen-free, silicone-free

Flammability: self-extinguishing acc. to UL94-V0 including gasket

Temperature: -40°C... +130°C (static)

RELATED PRODUCTS

- SPC grommets (from page 58)
- SPN grommets (from page 63)
- HY360 hydraulic punch driver (page 179)

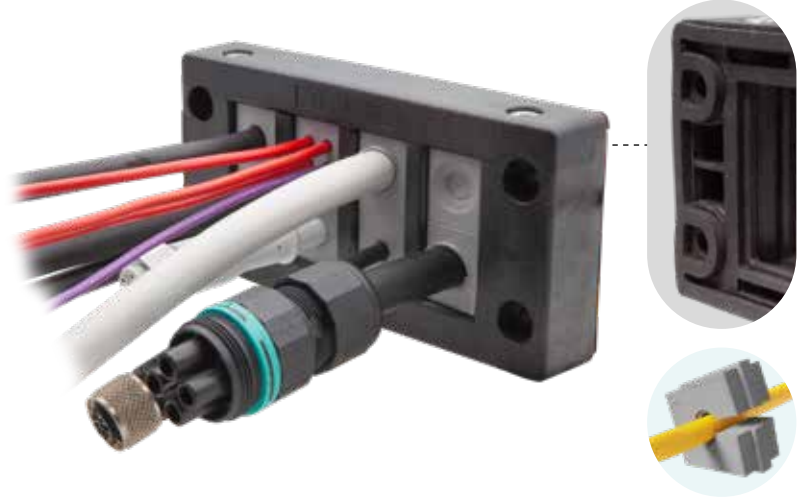

Model	Code	Some possible configurations	Cut-out (mm)	Pcs (/pack)
-------	------	------------------------------	--------------	-------------

NEW	DES LC16	1731010344		86 x 36	10
	DES LC16/2	1731010346		86 x 36	

ON REQUEST

Mounting screws	1731991020	Set of 4 mounting screws in AISI304 with Black Geomet finishing
-----------------	------------	---

DES LC16



DES LC16/2



Dimensions (mm)

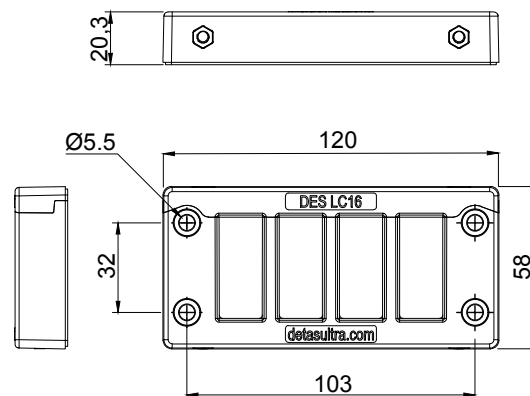

IP54

NEMA 12



IK10

