



# DES PDPS ATEX



Round base, cone-shaped cable entry grommets

## FEATURES

- For diameters from 23 to 64 mm
- Reinforcing base plate
- Cost efficient solution
- UL94-V0 for grey and black

The DES PDPS ATEX is available in two sizes, enabling non-terminated cables with diameter from 23 to 64 mm to pass through the walls of the electrical cabinets. The PDPS is installed from the front, without the need to screw the nut from the internal side of the wall. The reinforced base plate increases the stability when large cables are used.

**DES PDPS ATEX series can be used in zone 2 and 22.**

**Material:** TPE+PA, halogens and silicones free

**Flammability:** self-extinguishing acc. to UL94-V0

**Temperature:** -40°C... +110°C (static)

## RELATED PRODUCTS

- HY360 hydraulic punch driver (page 174)

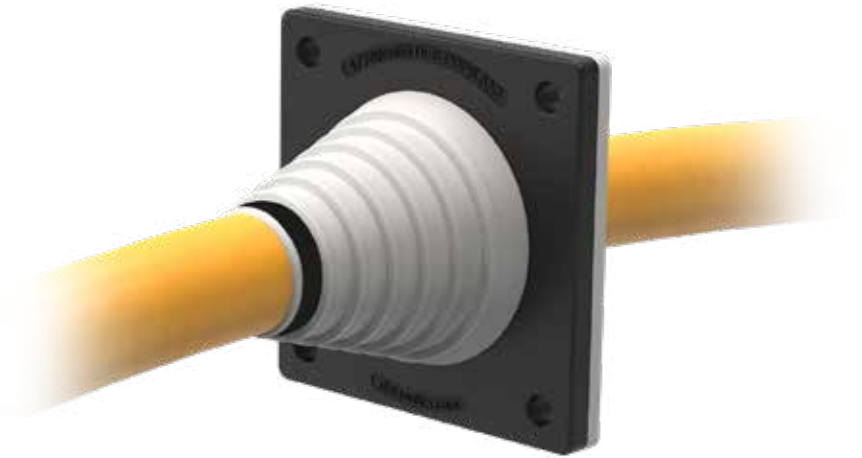

Model	Code	Nr. Cables	Ø Cable min/max (mm)	Ø Hole (mm)	Dimensions (mm)		Pcs x conf.
					Base	Height	
DES PDPS 63GA	1732352080	1	23 / 55	max 63,5	88 x 88	66	10
DES PDPS 75GA	1732352090	1	38 / 64	max 75,5	88 x 88	66	

## Dimensions (mm)

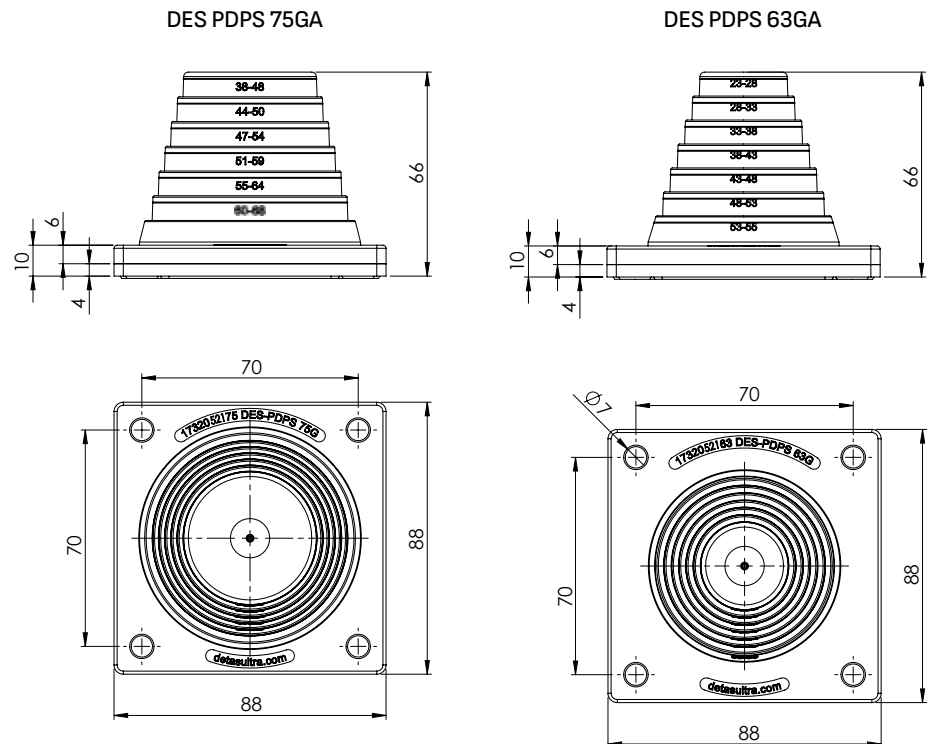

7



up to IP66

up to NEMA 12

UL TYPE 12



ECOLAB

UL94-V0



RoHS COMPLIANT

