



DES PMH 24



Cable entry plates with internal frame and double membrane

FEATURES

NEW

- Compact dimensions, ultra-thin
- For a large number of cables without connectors
- High strain relief thanks to the double membrane
- Space saving and cost efficient solution
- IP66
- Threaded inserts version on request



The DES PMH 24 is an innovative alternative to standard cable glands for machinery cabinets and equipment. Its ultra-thin design allows installation in limited spaces while maintaining excellent stability thanks to the integrated rigid frame. The cable is inserted through the front membrane, while the second membrane enhances strain relief and ensures liquid-tight sealing.

Material: TPE+PA66, halogens and silicones free

Flammability: self-extinguishing acc. to UL94-V0

Temperature: -40°C... +105°C (static)

RELATED PRODUCTS

- IFP plugs (page 112)
- DES PDM caps (page 112)
- Intumescent gasket (page 173)

NC: Number of cables

ØC: Diameter of cables - max (mm)

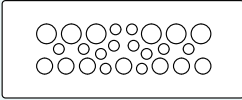
Model	Code		NC	ØC
DES PMH 24/25G	1732024025		6	7,5 / 12
Cut-out / Plate (mm)	Pcs/pack	7	4,8 / 9,7	
112 x 36 / 148,6 x 59,6	10	7	3,2 / 6,5	

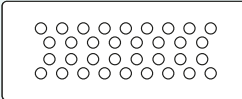
Model	Code		NC	ØC
DES PMH 24/34G	1732024034		34	3,2 / 6,5
Cut-out / Plate (mm)	Pcs/pack			
112 x 36 / 148,6 x 59,6	10			

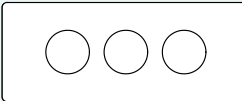
Model	Code		NC	ØC
DES PMH 24/3G	1732024003		3	23/31
Cut-out / Plate (mm)	Pcs/pack			
112 x 36 / 148,6 x 59,6	10			

Dimensions (mm)

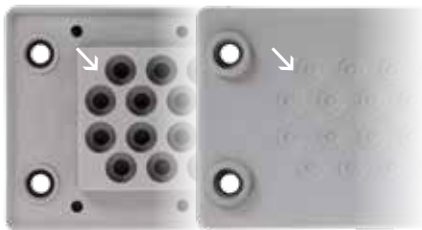

Double membrane

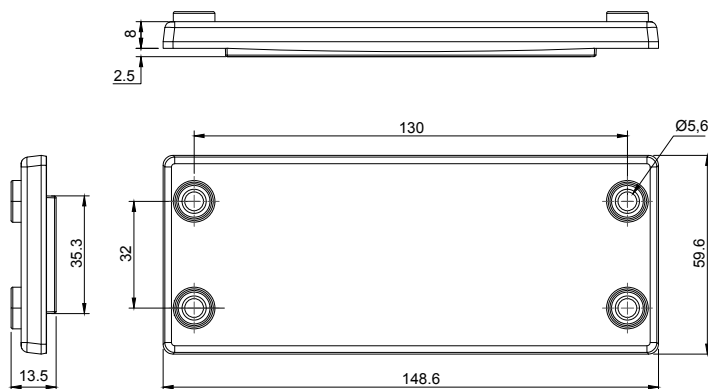

IP66



ECOLAB



RoHS COMPLIANT