



DES LC24

Splittable frame for cables with and without connectors

FEATURES

NEW

- For SPC and SPN grommets
- Stainless steel screws
- Strain relief according to EN 62444
- IP54
- Integrated UL94-V0 gasket

The DES LC24 is a splittable frame designed to accommodate various combinations of cables, with or without connectors. It is compatible with both small and large grommets from the SPC and SPN families. The gasket is pre-attached to the frame, allowing the DES LC24 to be installed directly onto the cabinet. Fixing is carried out using stainless steel screws. The frame's innovative polycarbonate (PC) material ensures superior resistance, particularly to extreme temperatures, compared to other commonly used materials.

Material: PP+GF, halogens and silicones free

Flammability: self-extinguishing acc. to UL94-V0 including gasket

Temperature: -40°C... +130°C (static)

RELATED PRODUCTS

- SPC grommets (from page 53)
- SPN grommets (from page 58)
- DES FLAP CLICK (page 39)
- HY360 hydraulic punch driver (page 174)



Model	Code	Some possible configurations	Cut-out (mm)	Pcs (/pack)
DES LC24	1731010340		112 x 36	10
DES LC24/2	1731010342		112 x 36	
ON REQUEST				
Mounting screws	1731991020	Set of 4 mounting screws in AISI304 with Black Geomet finishing		

DES LC24



DES LC24/2



Dimensions (mm)

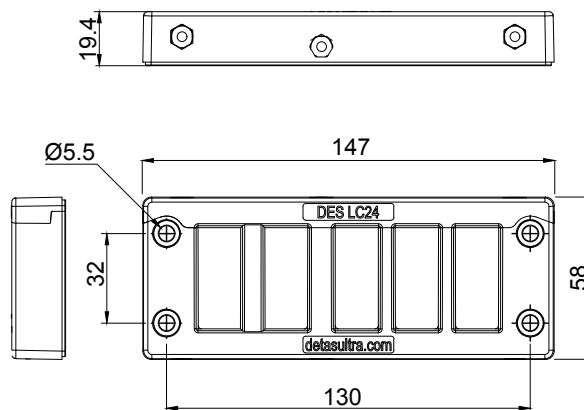

IP54

NEMA 12



IK10